

Reinforced bellow vacuum cups

Diameter 53 mm, with support, rubber

MATERIAL

Vacuum cup in oil-proof rubber (NBR), natural (NR), or silicone (VMQ).
Support in anodised aluminium.

STANDARD EXECUTIONS

- **VVQ-53-A**: oil-proof rubber, without support.
- **VVQ-53-N**: natural rubber, without support.
- **VVQ-53-S**: silicone rubber, without support.
- **VVQ-53-T-A**: oil-proof rubber, with support.
- **VVQ-53-T-N**: natural rubber, with support.
- **VVQ-53-T-S**: silicone rubber, with support.

FEATURES AND APPLICATIONS

They are specifically indicated for leafing through and picking up sheets of paper and cardboard, thin sheet metal and chipboard or pressed wood panels.

The reinforced bellows vacuum cup, wider and thicker than traditional bellows, allows a higher lifting force for the same size compared to normal bellows vacuum cups, combined with greater resistance to abrasion and wear, thereby improving its useful life.

The bellows configuration makes the vacuum cup usable even in conditions of imperfect flatness or inclined surfaces.

The effective stroke of the bellows is 16 mm.

See Technical Data for vacuum cups (on page -).

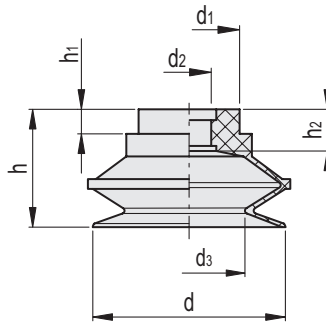

VVQ-53-A

Code	Description	d	d1	d2	d3	h	h1	h2	F* [Kg]	Volume # [cm3]	⚖
VV.61019	VVQ-53-A	53	27	10,5	30,5	35	6	9,5	5,51	30,5	18

VVQ-53-N

Code	Description	d	d1	d2	d3	h	h1	h2	F* [Kg]	Volume # [cm3]	⚖
VV.61020	VVQ-53-N	53	27	10,5	30,5	35	6	9,5	5,51	30,5	18

VVQ-53-S

Code	Description	d	d1	d2	d3	h	h1	h2	F* [Kg]	Volume # [cm3]	⚖
VV.61021	VVQ-53-S	53	27	10,5	30,5	35	6	9,5	5,51	30,5	18

* The force of the vacuum cups indicated in the table represents 1/3 of the value of the theoretical force calculated at a vacuum level of -75 KPa and a safety coefficient of 3.

Indicates the internal geometric volume of the vacuum cup and represents the volume to be added to the entire distribution circuit for the calculation of the evacuation time, especially if multiple vacuum cups are used.

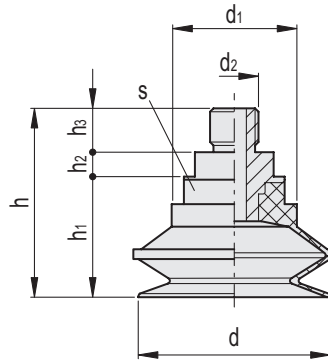

VVQ-53-T-A

Code	Description	d	d1	d2	h	h1	h2	h3	s	F* [Kg]	Volume # [cm3]	⚖️
VV.61022	VVQ-53-G1/4-T-A	53	27	G1/4	54.5	35	7.5	12	22	5.51	30.5	34

VVQ-53-T-N

Code	Description	d	d1	d2	h	h1	h2	h3	s	F* [Kg]	Volume # [cm3]	⚖️
VV.61023	VVQ-53-G1/4-T-N	53	27	G1/4	54.5	35	7.5	12	22	5.51	30.5	34

VVQ-53-T-S

Code	Description	d	d1	d2	h	h1	h2	h3	s	F* [Kg]	Volume # [cm3]	⚖️
VV.61024	VVQ-53-G1/4-T-S	53	27	G1/4	54.5	35	7.5	12	22	5.51	30.5	34

* The force of the vacuum cups indicated in the table represents 1/3 of the value of the theoretical force calculated at a vacuum level of -75 KPa and a safety coefficient of 3.

Indicates the internal geometric volume of the vacuum cup and represents the volume to be added to the entire distribution circuit for the calculation of the evacuation time, especially if multiple vacuum cups are used.